

# Project 4

---

## Pneumatic Gripper Assembly

In this project, you will create components for a Pneumatic gripper assembly and then assemble them. You need to create all the components as separate part files. The views and dimensions of the components are shown in Figures P4-3 through P4-10.

You can also download the model files for your reference from [www.cadcim.com](http://www.cadcim.com). To download the files, use the following path: *Textbooks > CAD/CAM > PTC Creo Parametric > Creo Parametric 7.0 for Designers > Projects for Free Download > Project 4*

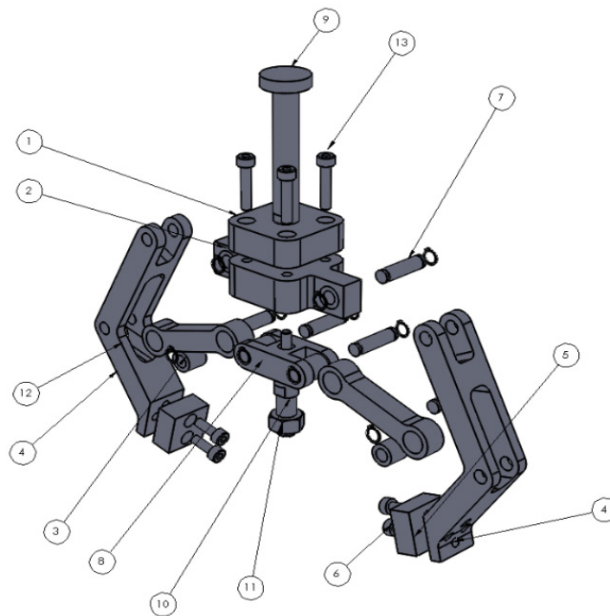

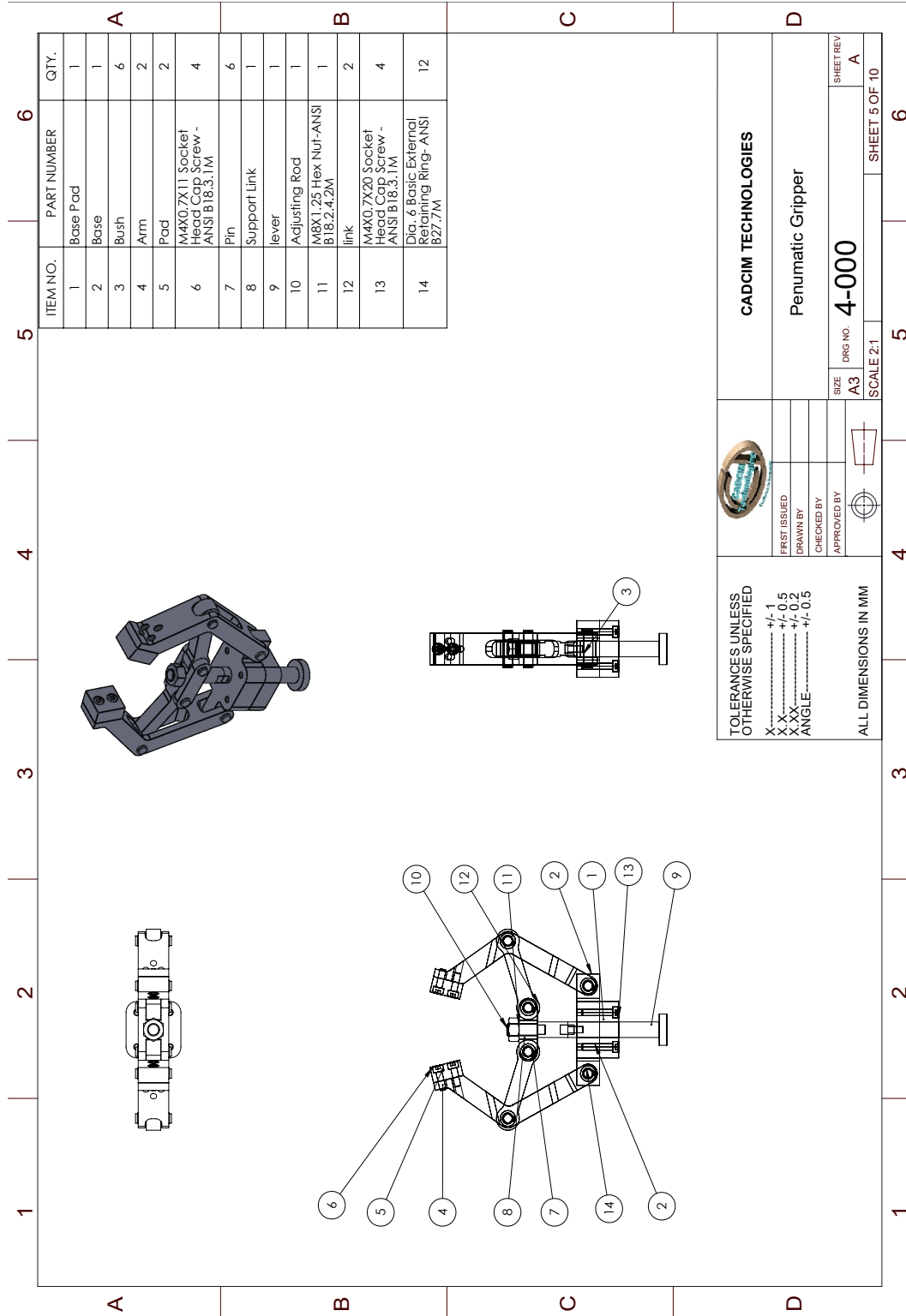

Figure P4-1 The Pneumatic Gripper assembly

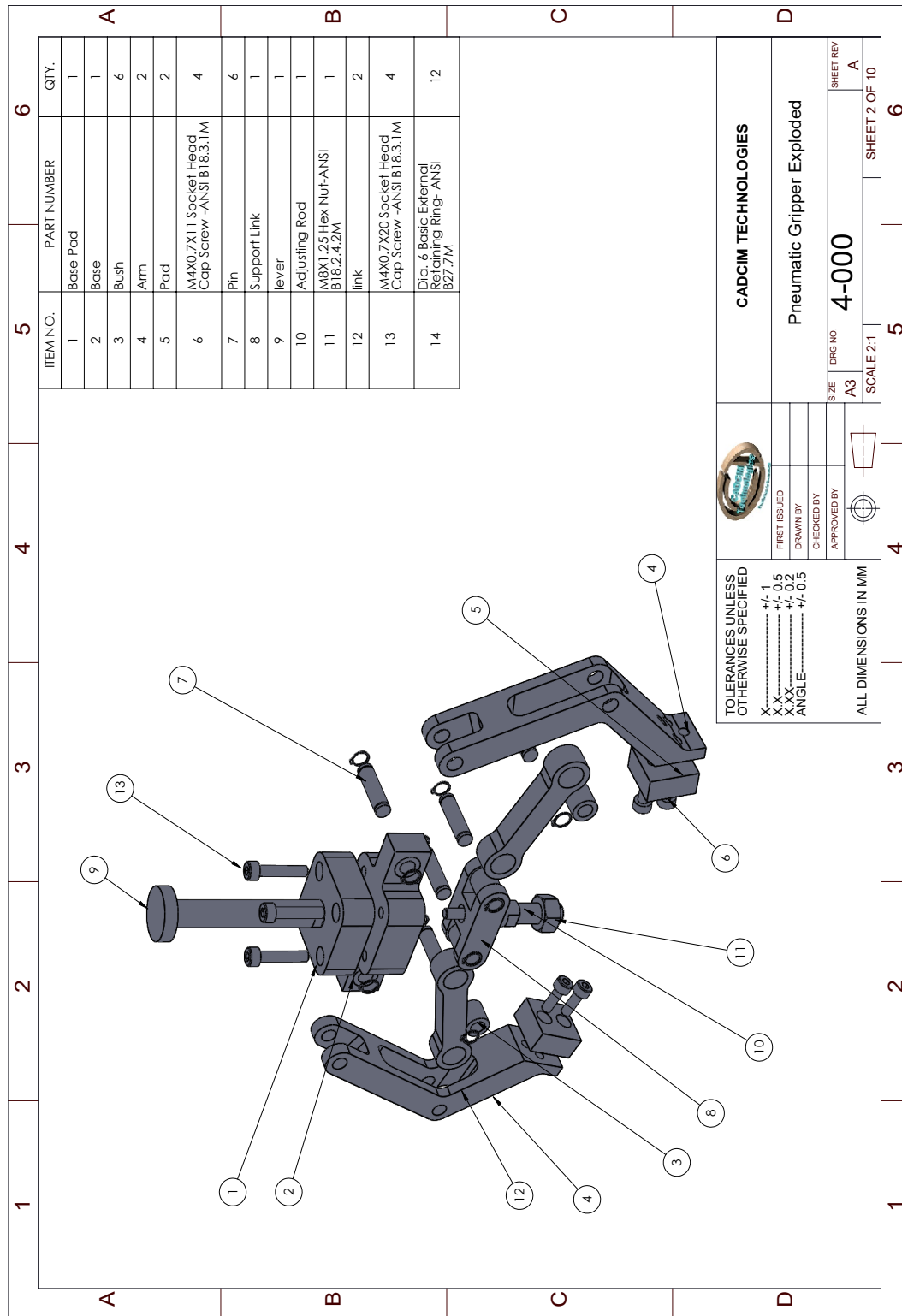

Figure P4-2 The exploded view of Pneumatic Gripper assembly

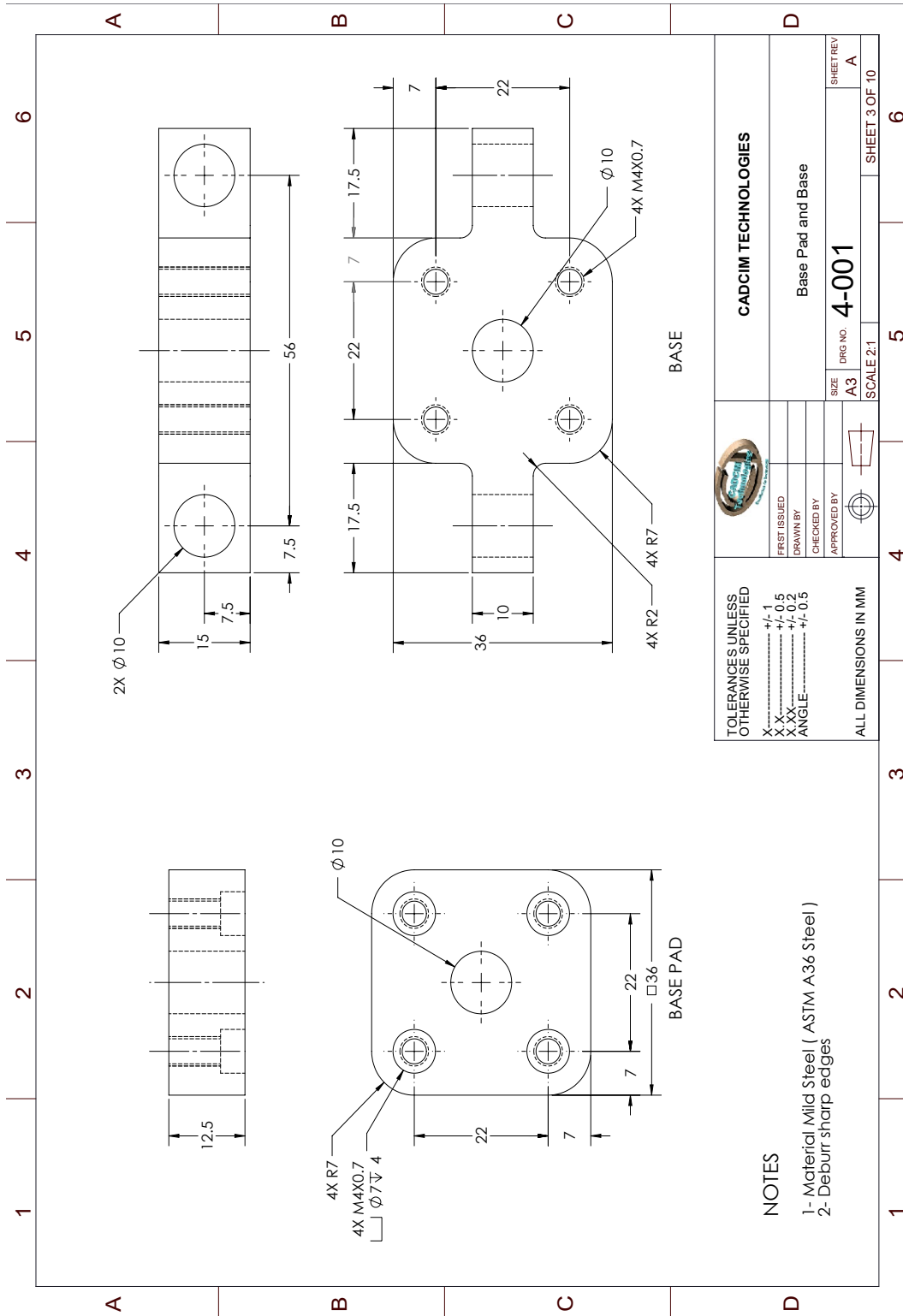

Figure P4-3 Views and dimensions of Base Plate and Base



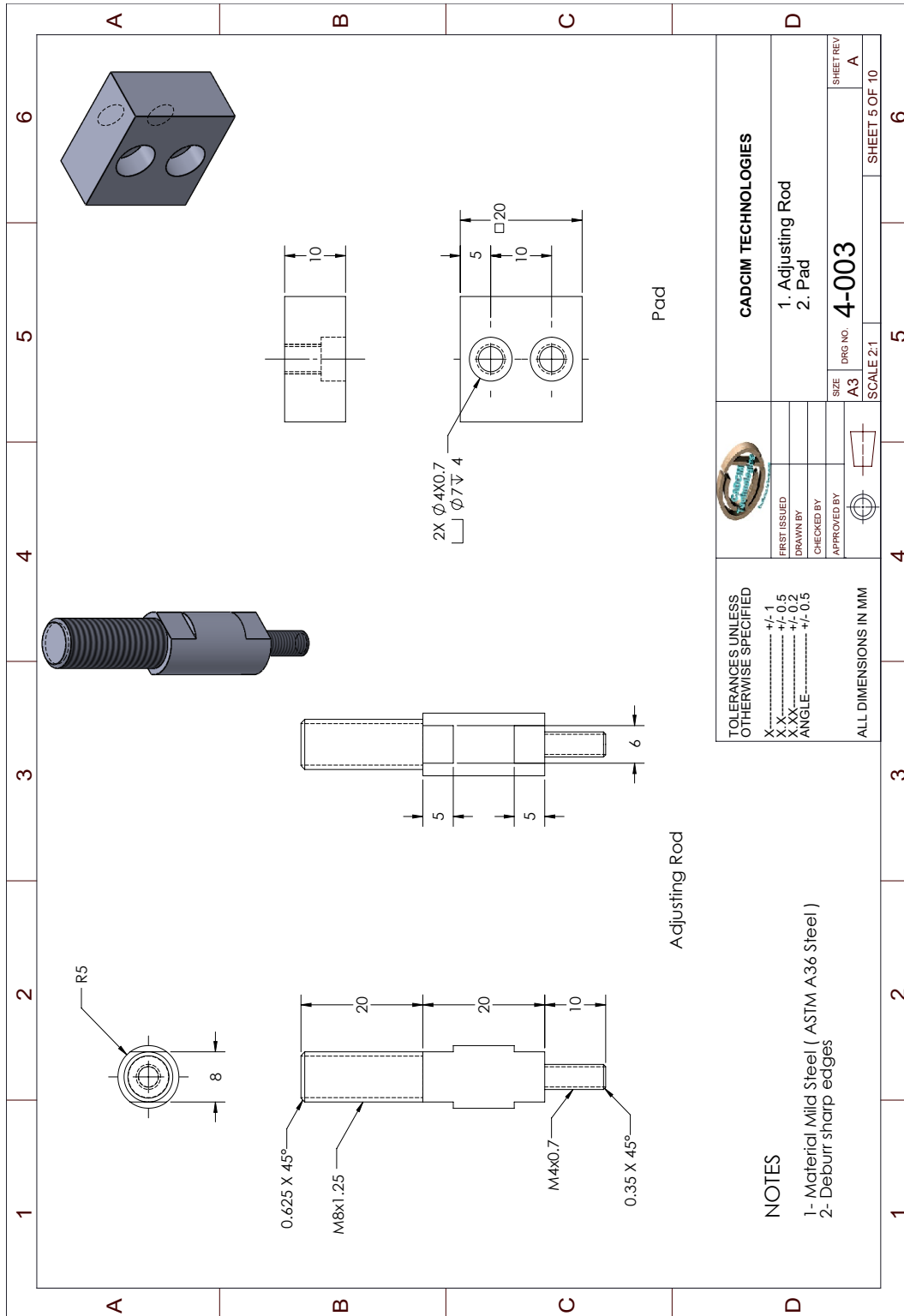

Figure P4-5 Views and dimensions of Adjusting Rod and Pad

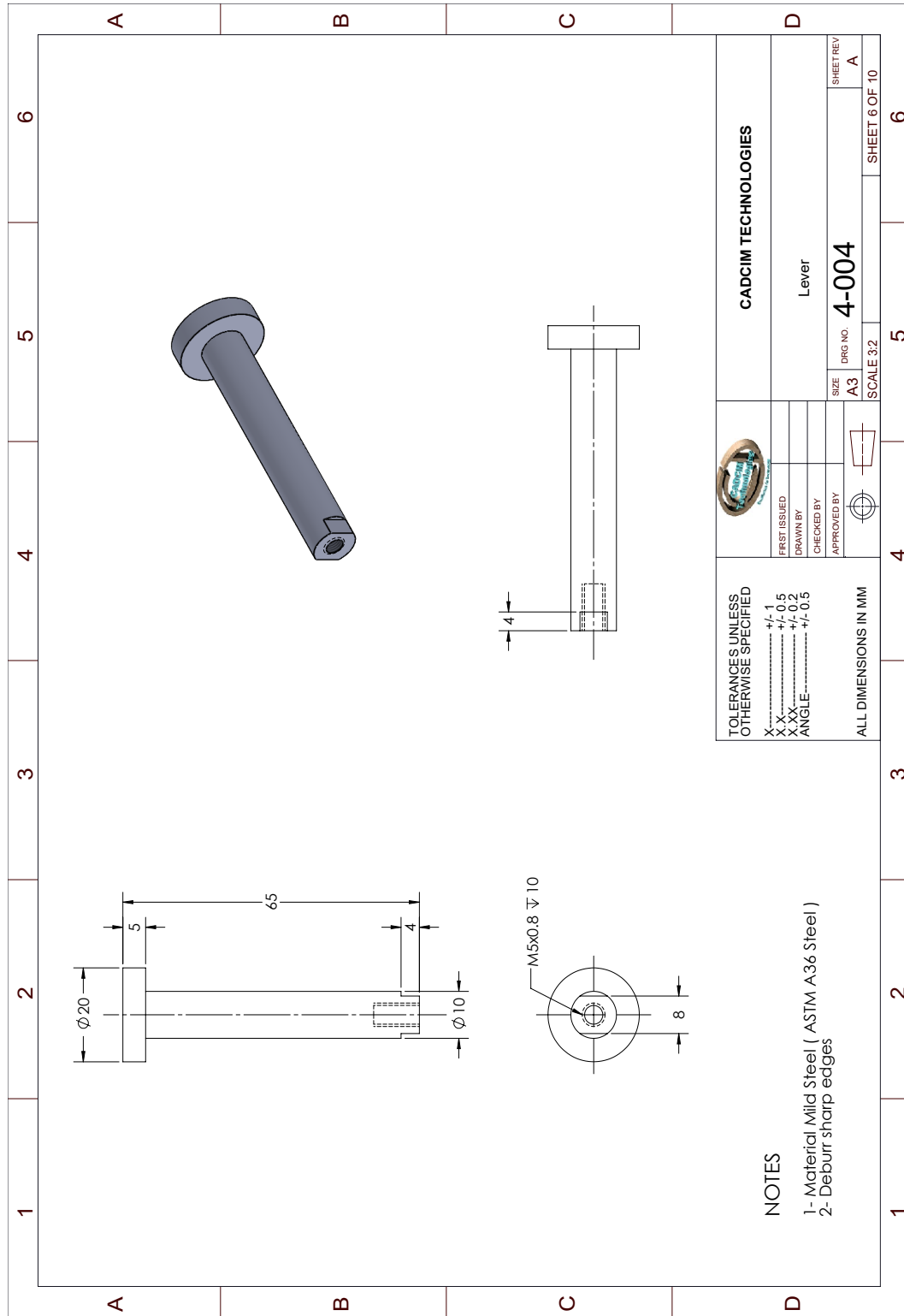

Figure P4-6 Views and dimensions of Lever

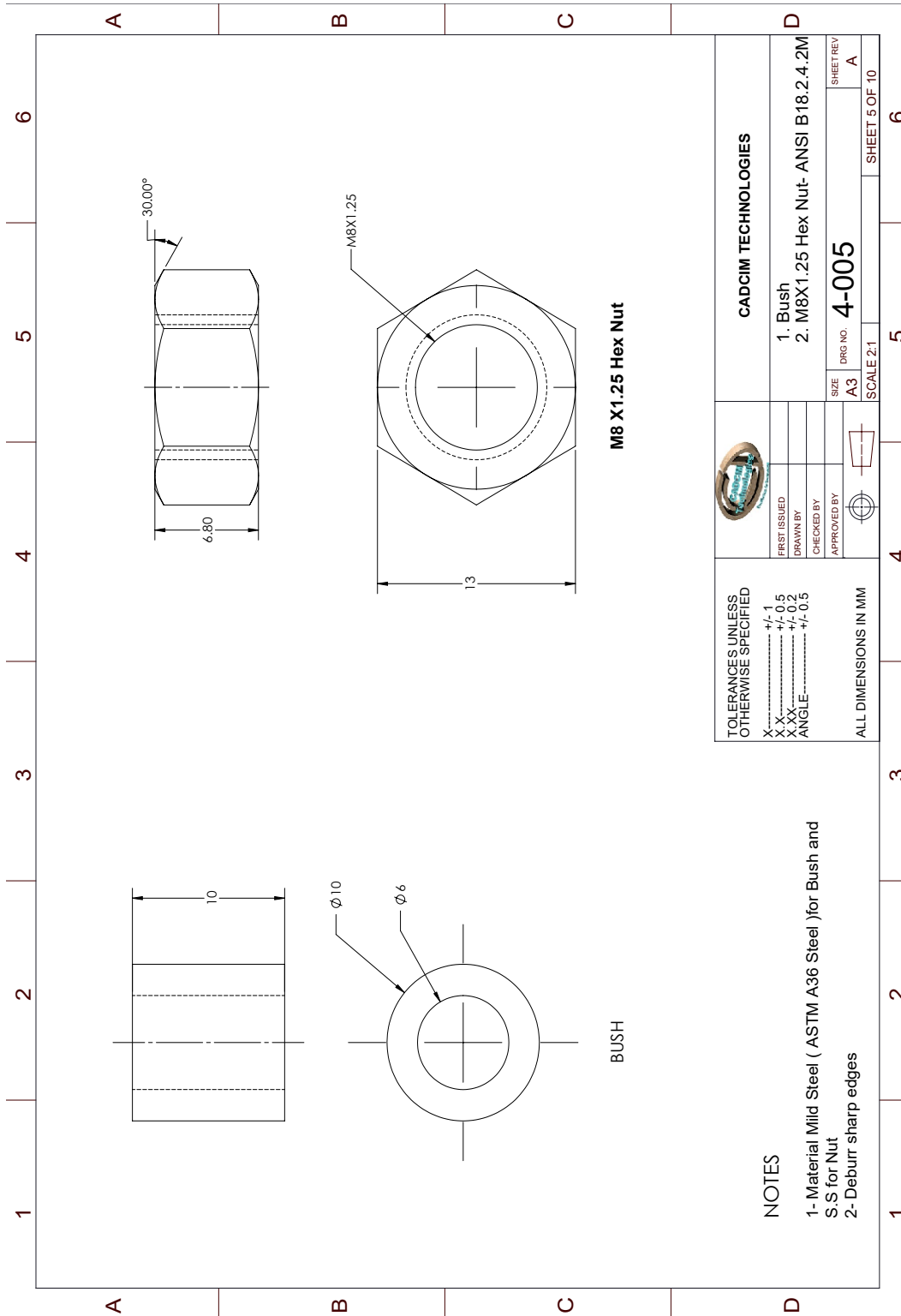

Figure P4-7 Views and dimensions of Bush and Nut



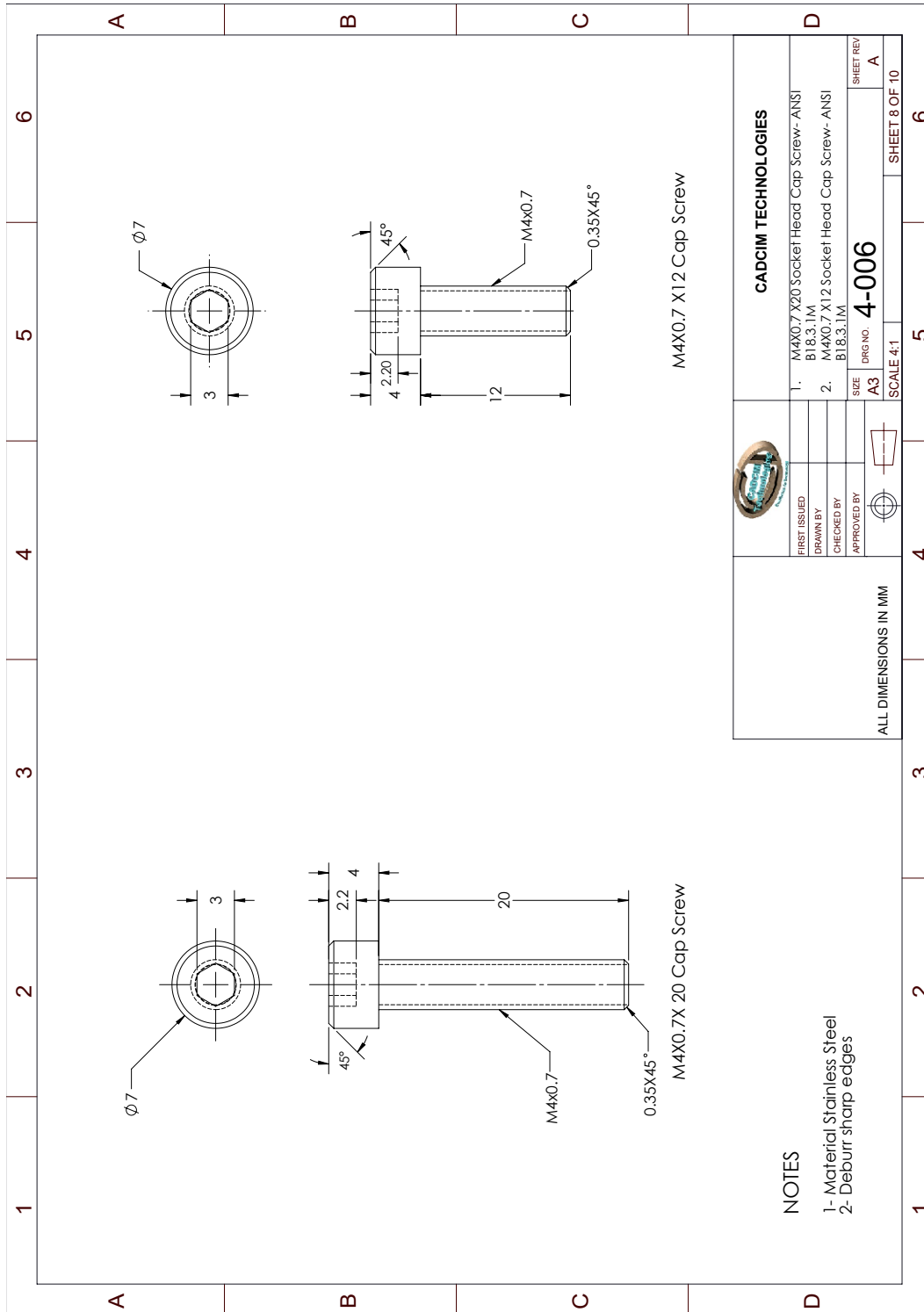

Figure P4-8 Views and dimensions of Cap Screws

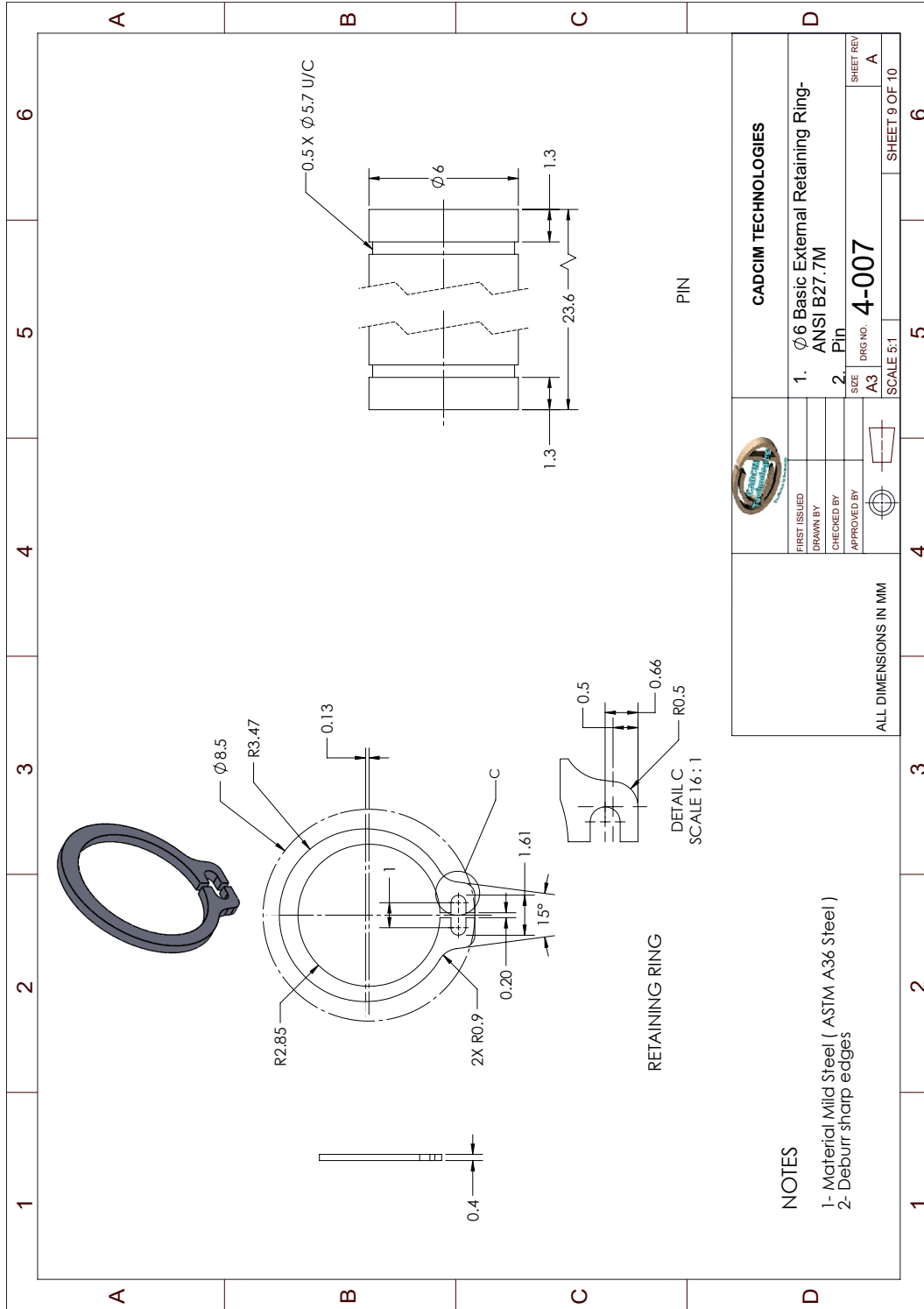

Figure P4-9 Views and dimensions of Retaining Ring and Pin

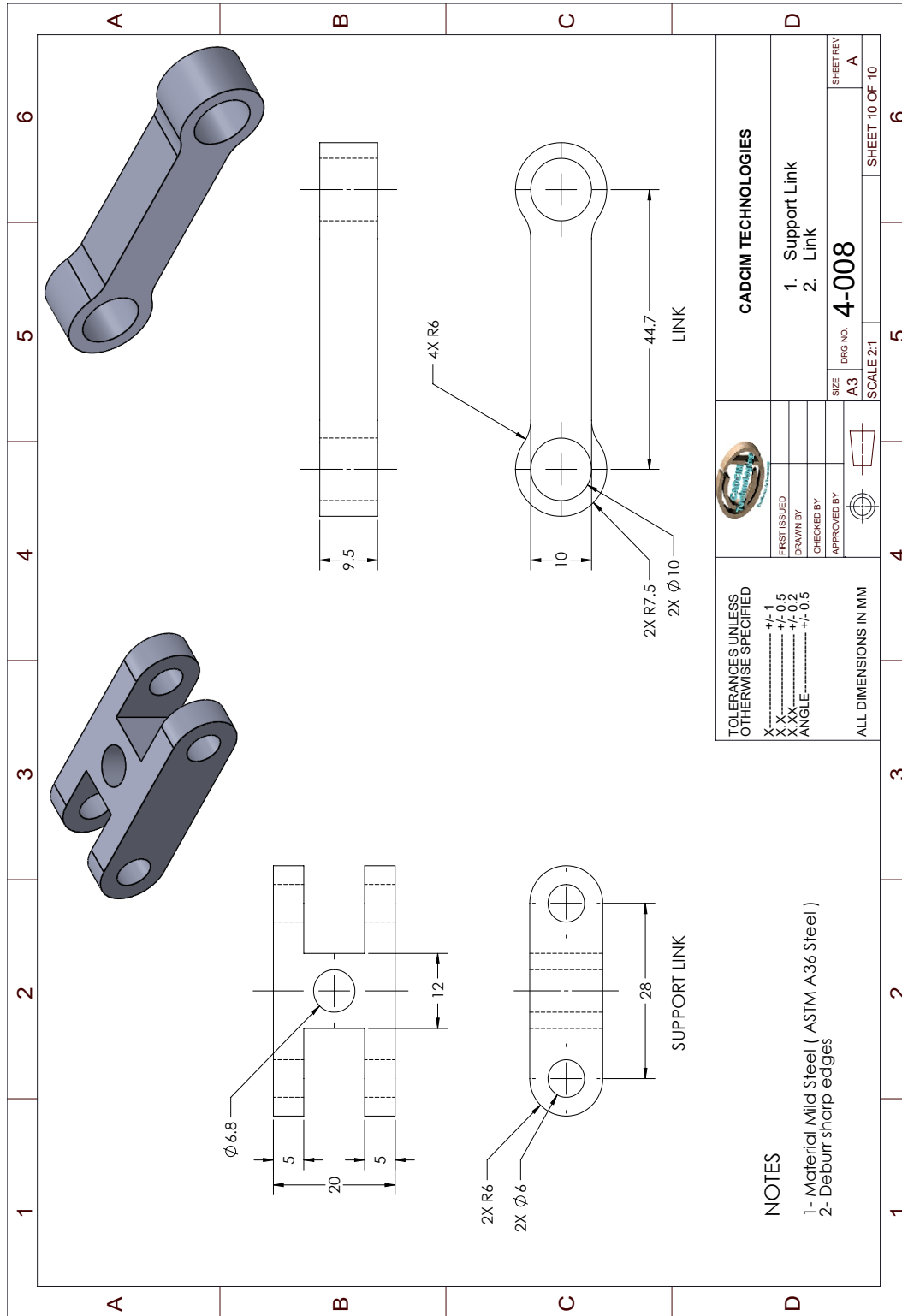

Figure P4-10 Views and dimensions of Support Link and Link

**This page is intentionally left blank**